



**POWER ON**

# The Future Homes Standard

Navigating the transition to low-carbon heat  
and what it means for high-rise  
developments and heat networks

# Webinar Presenters

Meet our experts



Artur Balint  
BUUK

Senior Regulatory  
Analyst



Alex Randall  
Power On

Business Lead -  
Sustainable Heat



Gareth Copeland  
Metropolitan

Operations Director



# Agenda

The Future Homes Standard Explained



Low Carbon Heat in Practice



Peace of Mind for Residents



Expert Panel



# The Future Homes Standard Explained



Artur Balint

Senior Regulatory Analyst

## In this section...

Definitions

---

Key Inclusions

---

Timeline for FHS Introduction

---

# Definitions

## Future Homes Standard

The Future Homes and Buildings Standard (FHS) is a major update to England's Building Regulations designed to ensure new homes produce 75–80% less carbon than those built under 2013 standards. It covers low-carbon heating, fabric performance, ventilation, and renewables, and forms part of the UK's commitment to reaching net zero by 2050.

## Future Homes Standard Implementation

The regulations were laid before Parliament on 24 March 2026 and come into force on 24 March 2027 for non-higher-risk buildings, and 24 September for higher-risk buildings, with a 12-month transition period. Projects with planning applications submitted before that date may still build under previous standards, meaning full mandatory compliance for all new homes and buildings in England is effective from March 2028.

## Home Energy Model

The Home Energy Model (HEM) is the UK Government's next-generation methodology for assessing the energy performance of domestic buildings. It replaces SAP with a half-hourly dynamic simulation of energy use, carbon emissions, and running costs.

## Higher Risk Building

Buildings that are at least 18 metres in height or 7 storeys, and contain at least 2 residential units.

## Non-Higher Risk Building

All other buildings.

# Key Inclusions

## Renewable Electricity Generation Requirement

New homes will be expected to include on-site renewable electricity generation, typically solar panels (equivalent to around 40% of ground floor area), with flexibility where full deployment is not feasible.

## Energy Performance Methodologies (Sap-hem Transition)

SAP will be used initially, with transition to the Home Energy Model (HEM), supported by a dedicated Government response setting out its development and implementation.

## Smart Meter Readiness

New guidance requires homes to be designed to enable smart meter installation from the outset.

## Existing Heat Networks

Can connect to new developments utilising sleeving and they must demonstrate that over the course of a year, at least 90% of the thermal energy calculated as delivered to the new building or dwelling by a heat network (in kWh) is provided by low-carbon heat sources, including distribution losses.

## Infrastructure Planning And Early-stage Coordination

Across the policy package, there is a clear emphasis on planning infrastructure requirements upfront.

# Timeline for FHS Introduction

2026

**24<sup>th</sup> March 2026**  
Publication of FHS.

2027

**24<sup>th</sup> March 2027**  
FHS comes into force for non-higher-risk buildings.

**June 2027**  
Expected date for HEM approval.

**H2 2027**  
HEM-based EPCs launch, relacing SAP.

**24<sup>th</sup> September 2027**  
FHS comes into force for higher-risk buildings.

2028

**24<sup>th</sup> March 2028**  
FHS transitional period ends for non-higher-risk buildings. All projects must be FHS buildings.

**24<sup>th</sup> September 2028**  
FHS transitional period ends for higher-risk buildings. All projects must be FHS buildings.

**24+ months after HEM approval**  
SAP withdrawn as an FHS compliance route. HEM becomes the sole methodology.

2030

**2030**  
All new non-higher-risk buildings completed expected to be FHS compliant.

2031

**2031**  
All new higher-risk buildings completed expected to be FHS compliant.

Within this period, projects that have already received permission will not need to be FHS compliant. New permissions will need to be FHS compliant.

Within this period and going forward, all projects will need to be FHS compliant

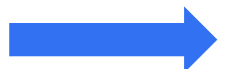

# Low carbon heat in practice



Alex Randall

Business Lead - Sustainable Heat

## In this section...

The Energy Trilemma

Balancing Act

Heat Networks Regulation Timeline

Zoning

FHS – What's Out vs What's In

Our FHS Compliant Heat Networks

Centralised Air Source Heat Pump

Networked GSHP Solution

Customer Bill Comparison

Design, Build, Adopt, Operate

# The Energy Trilemma

Low-carbon heat is no longer optional, it is essential. As regulation tightens, consumer expectations evolve, and climate pressures intensify, the need for scalable, high-performance solutions becomes ever more urgent. Power On's networked ground source heat pump system enhanced by smart control from Passiv UK, meets that need head-on. It provides a future-ready answer to the UK's energy trilemma: ensuring homes that are secure, affordable, and sustainable by design.

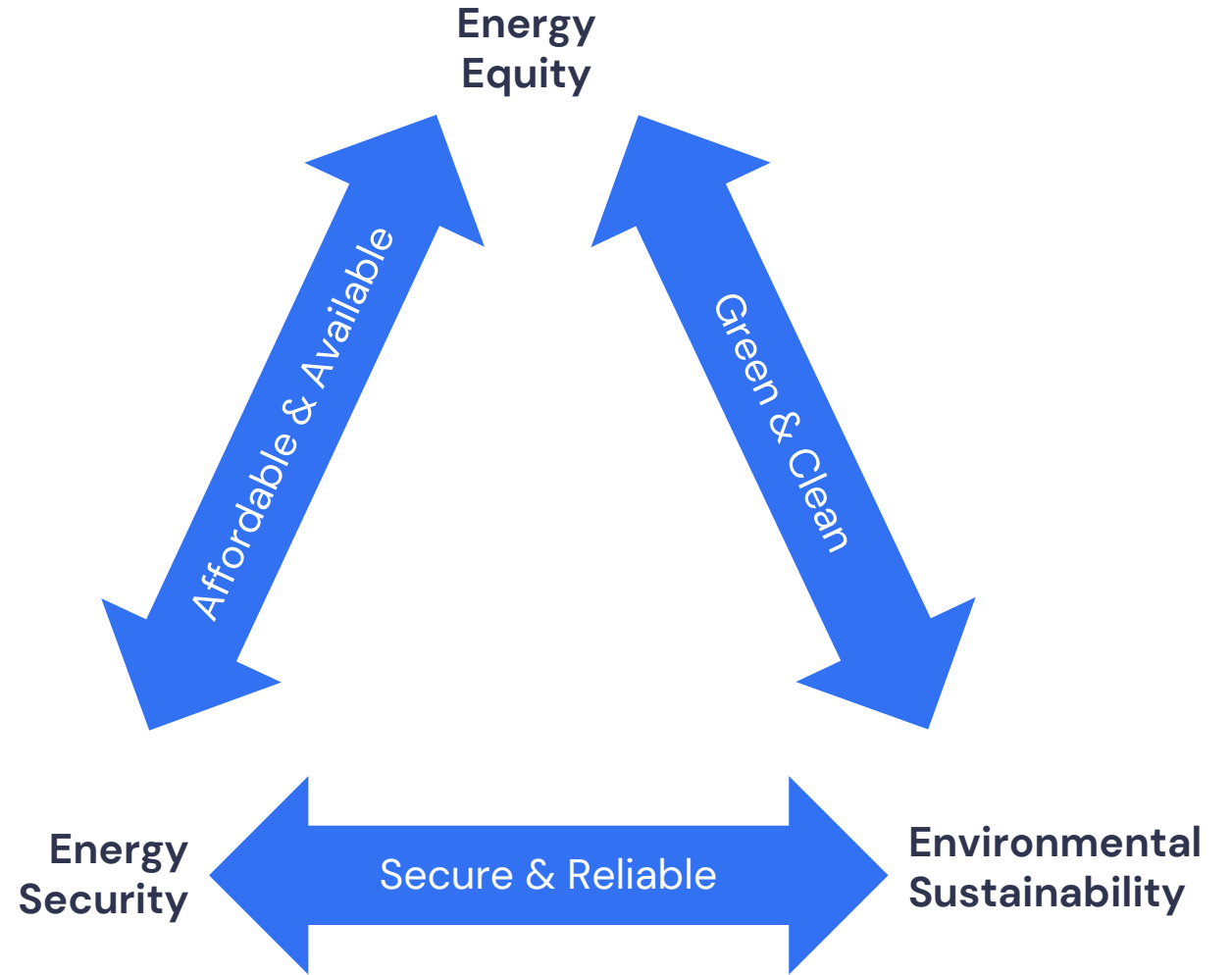

For developers committed to delivering net zero communities and futureproof homes, Power On offers more than just heat. It offers leadership, compliance, and long-term value embedded in the ground beneath every home.

# The Balancing Act

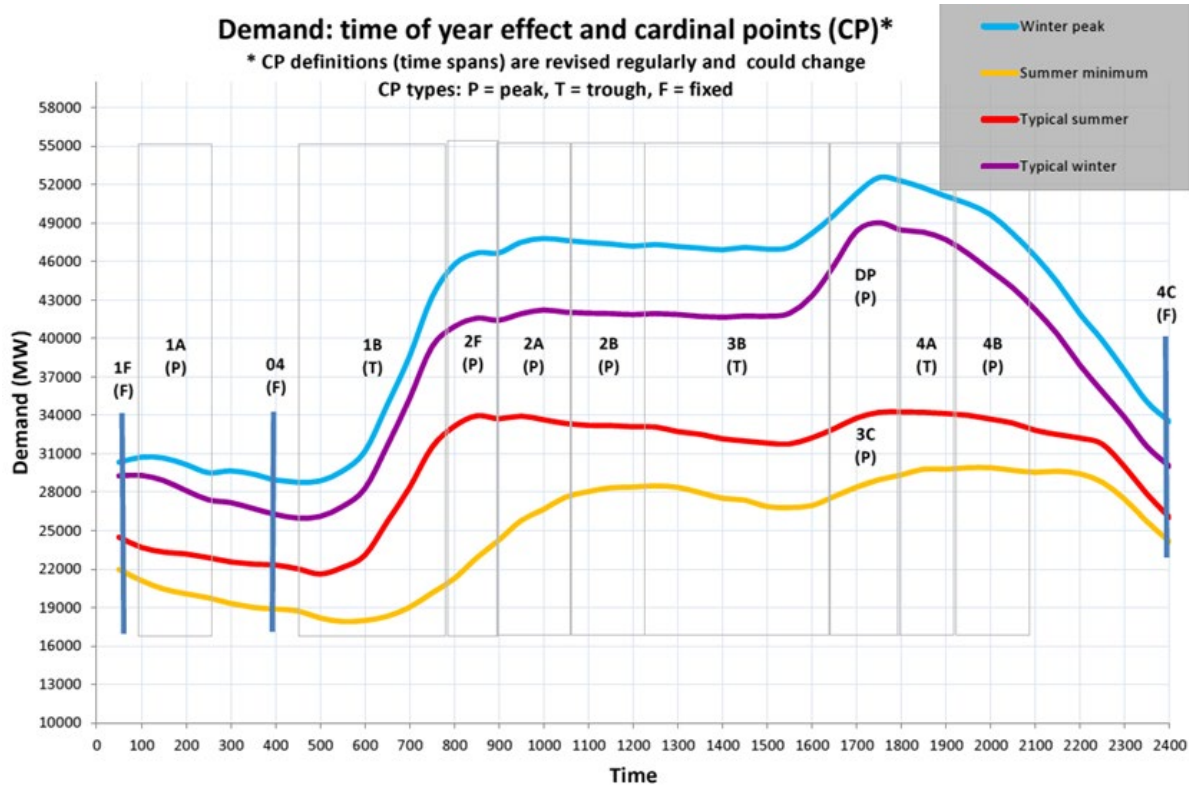

- Grid system is rigid
- Negative energy – Pay generator to turn off
- Flatten the load profile – Solar PV & EV at night
- Require more flexibility – Smart Homes
- Flatten the curve- solving the “Affordable & Available”
- Capacity Challenge – AI & Data Centres

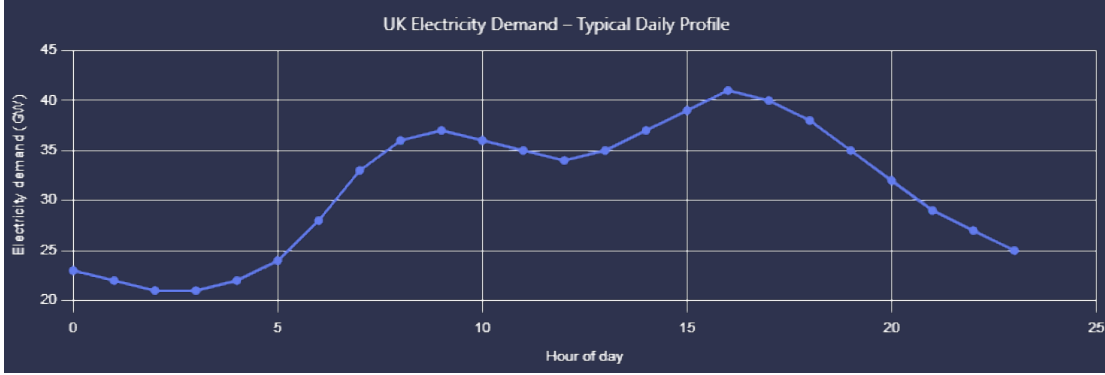

# Heat Networks Regulation Timeline

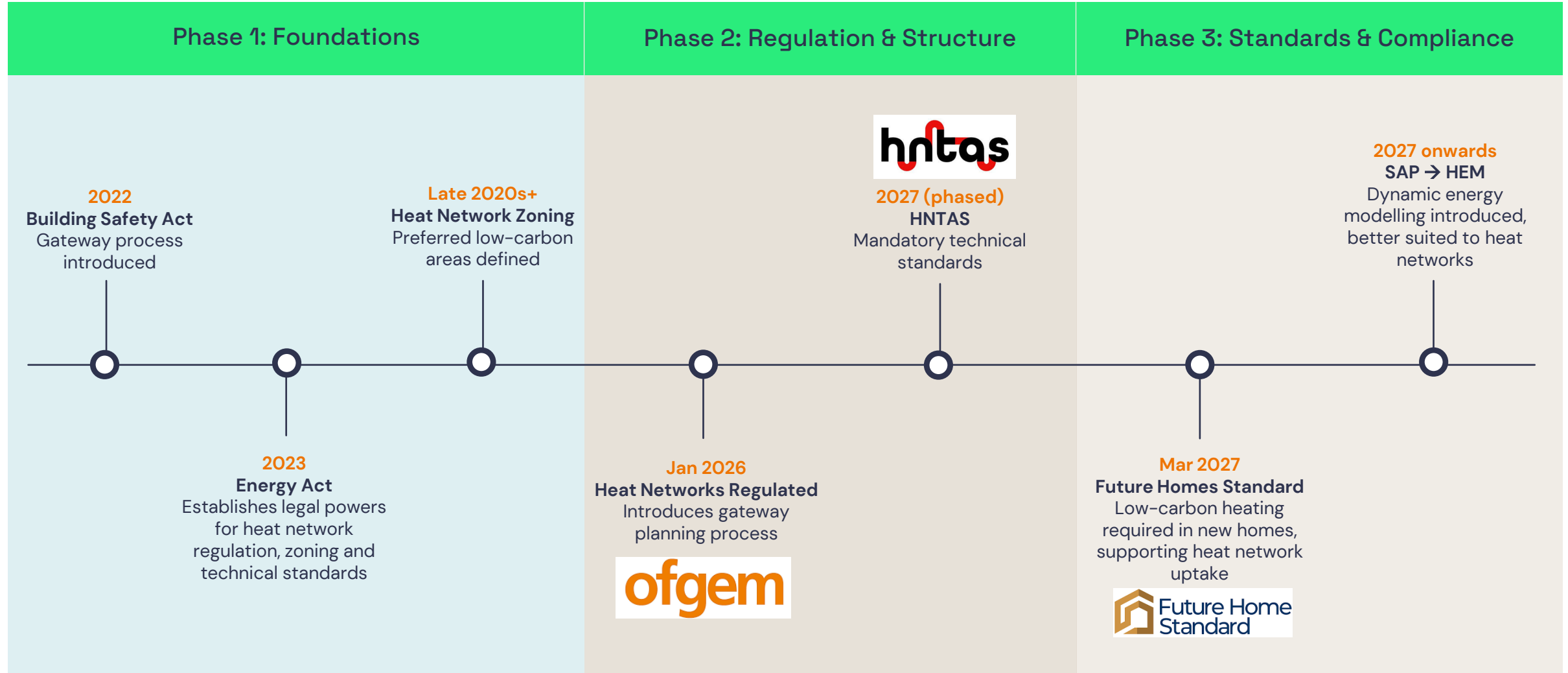

# Zoning

Pending announcement Spring '26

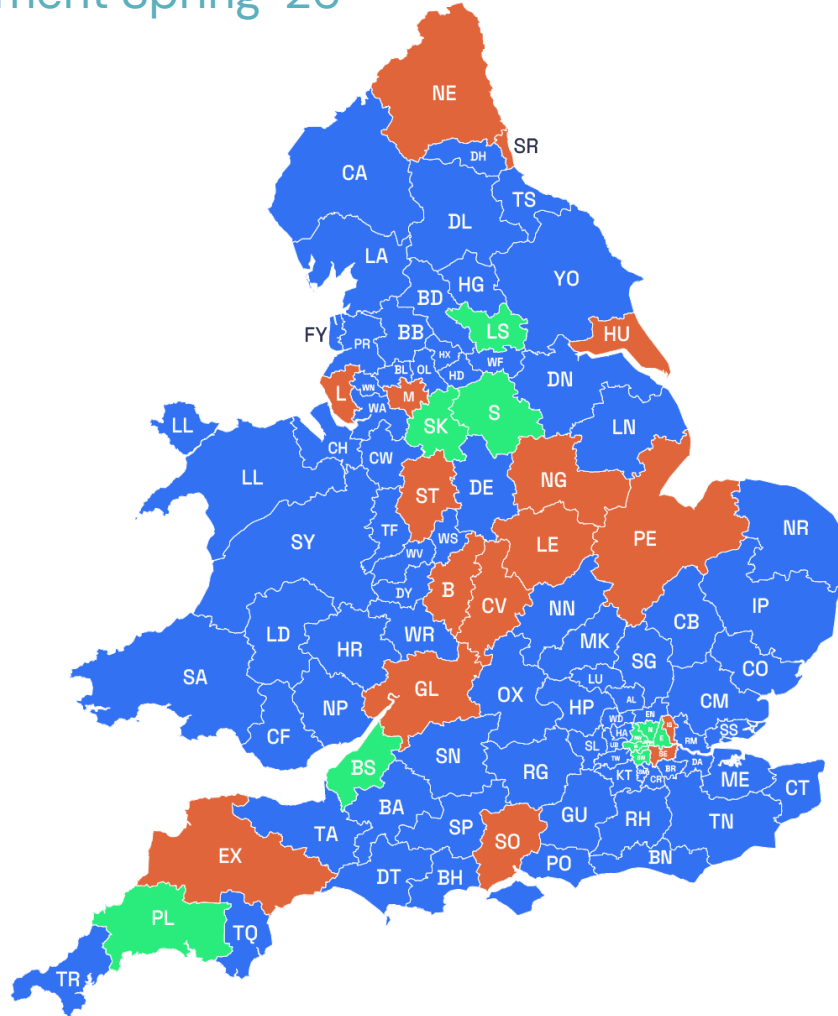

## 6 Pilot Zones

- Leeds
- Plymouth
- Bristol
- Stockport
- Sheffield
- London

Heat network zoning in the UK is a strategic policy designed to accelerate the rollout of district heating by identifying specific geographic areas in cities and towns where heat networks are the lowest-cost, low-carbon solution for heating buildings

## 25 Future Zones





- Birmingham
- Bristol
- Cheltenham
- Coventry
- Exeter
- Gateshead
- Greater Manchester x4
- Hull
- Leeds
- Leicester
- Liverpool
- London (Barking & Dagenham, Southwark)
- Newcastle
- Nottingham
- Peterborough
- Plymouth
- Sheffield
- Southampton
- Stoke-on-Trent
- Sunderland

# Future Homes Standard

## What's out (or almost impossible) VS what's in





The Future Homes Standard shifts away from individual, carbon-intensive systems towards networked, low-carbon heat solutions.

### **What's Out** (or almost impossible)

-  Oil
-  Gas
-  Biomass
-  CHP
-  Direct Electric Heaters

VS

### **What's In** Future-ready solutions

-  Low carbon heat networks
-  Centralised heat pumps
-  Ambient loop systems
-  Individual ASHP (planning permitted)
-  Systems designed for future network connection

# Our FHS compliant Heat Networks

Developer	Site	Units
Taylor Wimpey	Gilston, Harlow	1,500
Taylor Wimpey	Wisley, Surrey	2,200
Taylor Wimpey	Swinnow Park, Leeds	762
Taylor Wimpey / Dorchester Living	Prince Phillip Park, Bordon	1,093
Vistry	Hopfields	2,042
Riverside(Countryside)	Pike Close	170
Riverside (Countryside)	Calverley Close	270
Peabody	Dagenham Green	935
Taylor Wimpey	East Riverside (Leven Rd)	530
Ballymore	Embassy Gardens (KenPart)	247
Peabody	St Anns Hospital	929
Bellway	Ebbsfleet	56
Chartway Group	Swantree Ave	135
Vistry	Ford Airfield	1500
Chartway Group	Pennine Way	250
Timmins Land Solutions	Fiddington	221
Taylor Wimpey	Nouale Lane	200
JSJ Assets	JSJ Assets	60
Akehurst Homes	Avery Nursery	53
Persimmon Homes	Huges Land	281
Allsion Homes	Quarry Farm	650
Wilcox Homes	Willington Fen Marina	155
Jomast	Hartlepool Marina	600
Berkeley	Oval	1,387
Bellway	Lambeth Riverside	441
Berkeley	Green Quarter	2,538
<b>26 under construction/adoption</b>		<b>19,205</b>

**Taylor  
Wimpey**

**Westland Heath**  
1,000 residential units

**Vistry**

**Bexhill**  
801 residential

# Community Heat Hub

We are designing, building and adopting schemes right now that are Future Homes Standard-compliant, zero-carbon-ready and heat regulation aligned.

Minimum 400+ units

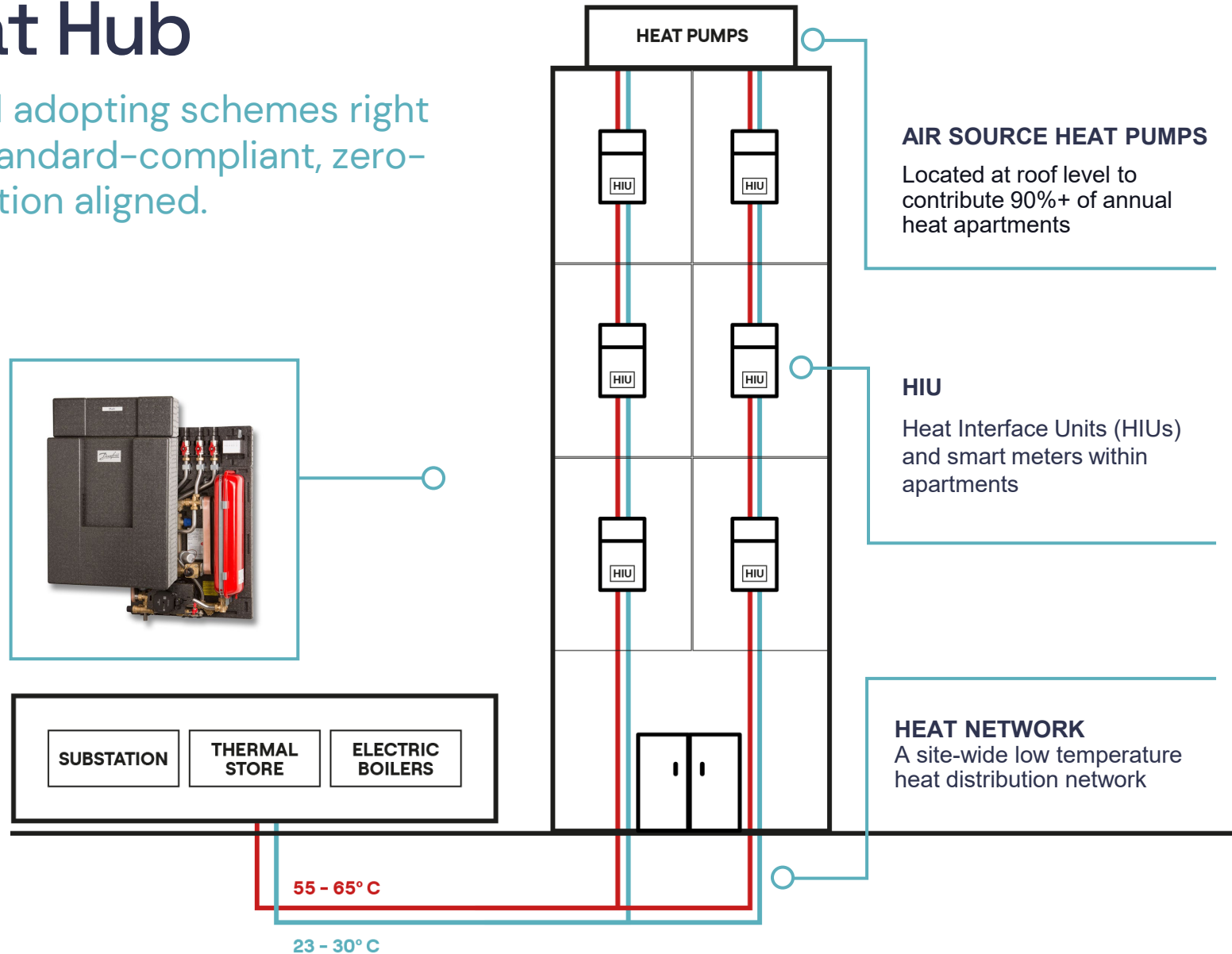

## MAIN PLANT ROOM (either at ground floor or basement level)

- Electric boilers, for stand-by and peaks
- Thermal stores to give operational flexibility
- Auxiliary plant including water treatment, etc.
- Delivered as pre-fabricated modules assembled on site



# Networked GSHP Solution

## Ambient Loop

Minimum 100+ units

- ✓ **Kensa Shoebox NX 5.5kW**  
Offers enhanced efficiency and performance.
- ✓ **3-4 units (kWh) of heat for each unit of electricity**  
Much more efficient than individual air source heat pumps.
- ✓ **Dimensions of Shoebox NX**  
627mm X 554mm x 570mm.
- ✓ **Designed for quiet operation**  
The Shoebox NX makes less noise than some boilers.
- ✓ **Requires minimal maintenance**  
25+ year life expectancy.

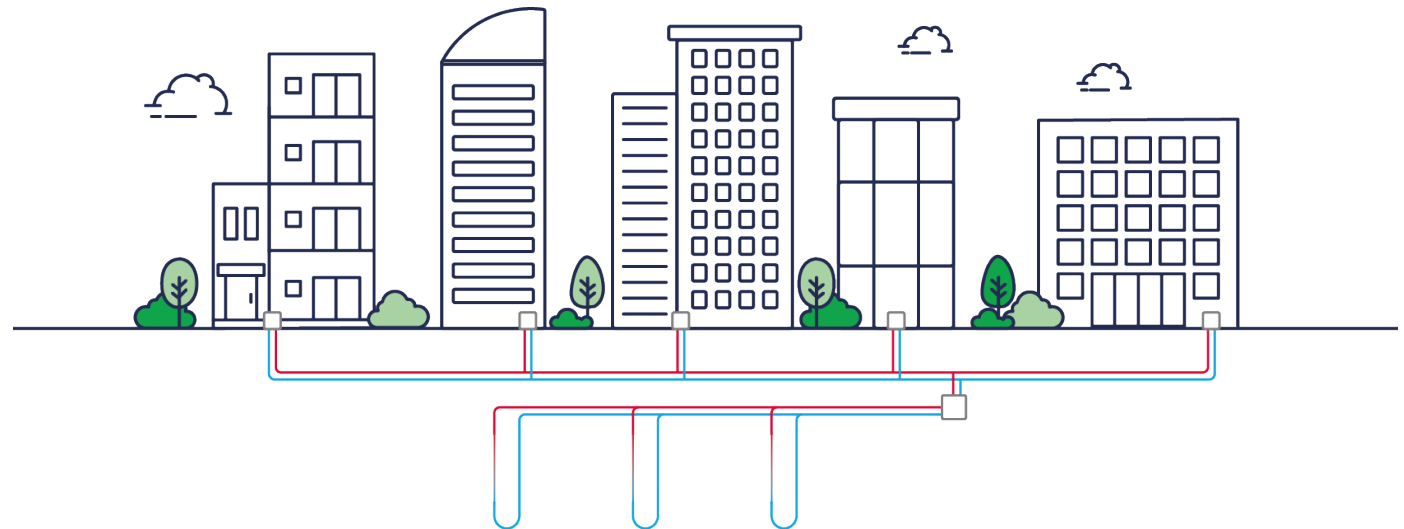

# Customer Bill Comparison

For varying heat solutions

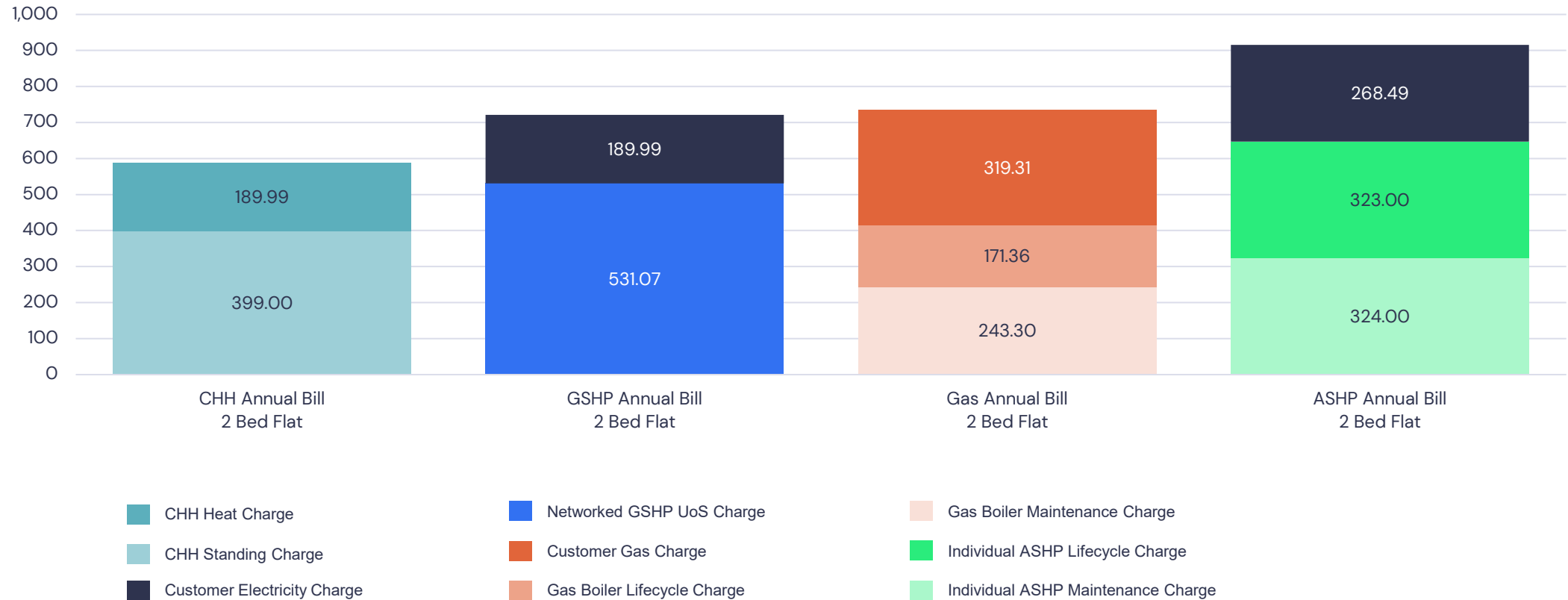

# Pre-future Homes Standard Low Carbon Sites

We were on site delivering these solutions well in advance of the formal FHS announcement.



Chilton Woods



Ebbsfleet



Swinnow Park

# Design, Build, Adopt, Operate

The sooner we get involved, the more advantageous it will be. By reducing the electrical capacity requirement, we ensure a flexible, robust, and optimised design is at the core of decisions from day one.

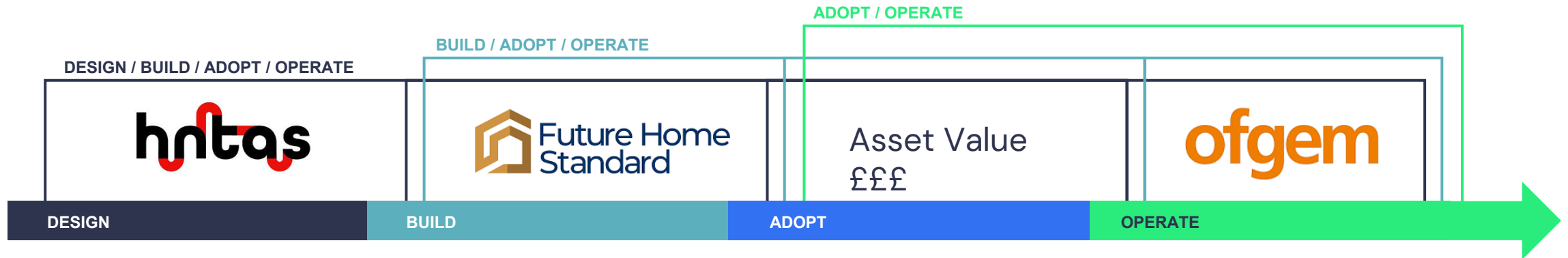

## End-to-end low carbon heat

Power On offers an end-to-end service covering every stage of your project. Whether it's designing and constructing the network, facilitating its adoption, or ensuring seamless ongoing operation, we can help at any stage of the journey.

**Power On** - we provide developer an Asset Value for the adoption

# Peace of Mind for Residents



Gareth Copeland  
Operations Director

In this section...

Post-Build Ownership & Adoption

---

# Post-Build Ownership & Adoption



## End-to-End Ownership Model

- Full adoption of the heat network following construction
- Long-term ownership and operational accountability
- Regulatory compliant model



## Services Included

- Operation & Maintenance of all heat network assets
- Lifecycle Replacement, planned, funded, and delivered
- Customer Billing & Service, metering, invoicing, and customer support



## Key Benefits

- Risk & Responsibility Transfer
- We are the regulated Heat Network Operator, carrying all post-construction regulatory risk
- We own all customer debt risk
- Single point of contact for customers



## Proven Track Record

- Confidence for Developers & Customers
- Long-standing, best-in-class service delivery
- Price Promise
- Guaranteed annual customer costs equal to or lower than an alternative heating solution

# Q&A

## Panel



Artur Balint  
BUUK

Senior Regulatory  
Analyst



Alex Randall  
Power On

Business Lead -  
Sustainable Heat



Gareth Copeland  
Metropolitan

Operations Director



Bruce Geldard  
Metropolitan

Engineering Director

# POWER ON<sup>®</sup>

Fletcher House, Redgrave Close,  
Parkway, Coventry CV2 2UU

---

[enquiries@poweron-uk.co.uk](mailto:enquiries@poweron-uk.co.uk)

03453 223322

---

[poweron-uk.co.uk](http://poweron-uk.co.uk)

---

**Alex Randall, Business Lead for Sustainable Heat**

[Alex.randall@poweron-uk.co.uk](mailto:Alex.randall@poweron-uk.co.uk)

+44 7525 818 359

Electricity Water Wastewater Fibre Heat Gas

All Utilities. One Provider.